

CDI

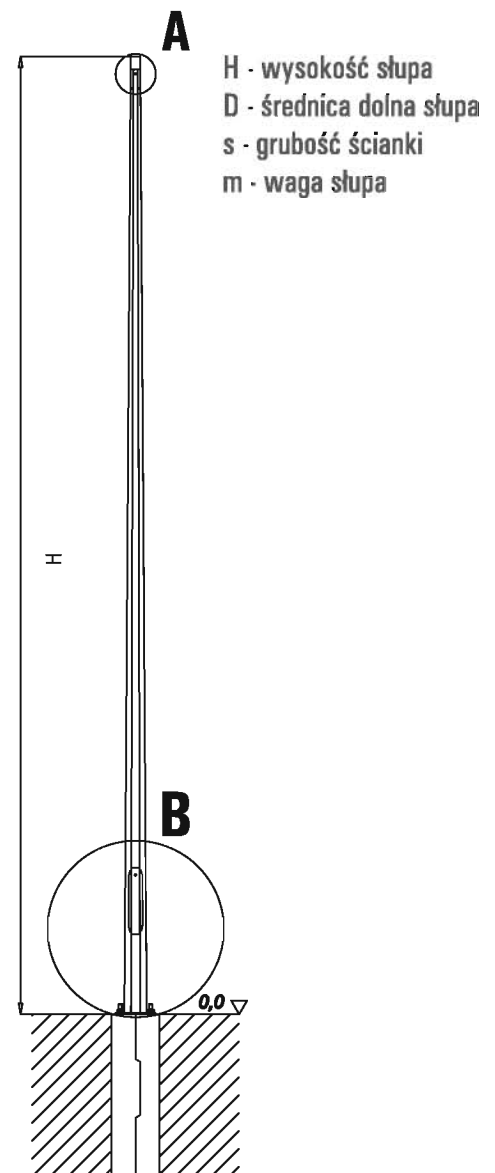

Przykładowe rozwiązania

Widok ogólny



Szczegóły techniczne

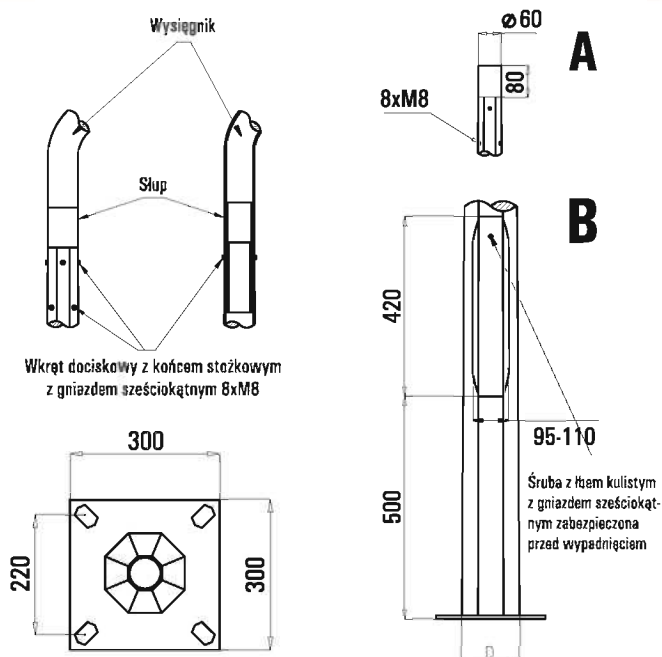

Typ słupa	H [mm]	D [mm]	s [mm]	m [kg]
CDI 7/3	7000	150	3	60
CDI 8/3	8000	162	3	71
CDI 7/4	8000	162	4	93
CDI 9/3	9000	174	3	82
CDI 9/3	9000	174	4	108
CDI 10/3	10000	186	3	96
CDI 10/3	10000	186	4	124